

MEMS Capacitive Accelerometer

ASC CS-1511LN | ASC CS-1611LN

Biaxial, Triaxial
 MEMS Capacitive
 Measurement Range: ± 2 to ± 50 g
 Output Signal: 4-20 mA
 Frequency Range ($\pm 5\%$): DC to 2000 Hz
 Aluminum Housing
Made in Germany

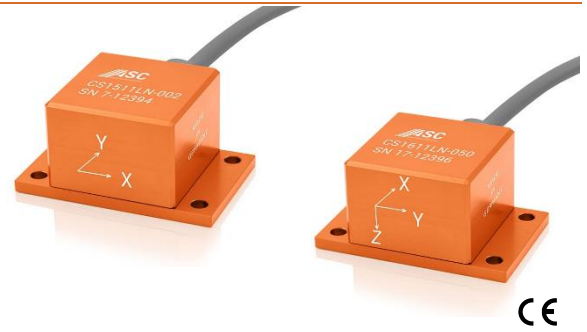

MEMS Capacitive Accelerometer

The key components in capacitive accelerometers are high-quality micro-electro-mechanical systems (MEMS) that feature excellent long-term stability and reliability. This technology enables the measurement of static (DC) and constant accelerations, which can be used to calculate the velocity and displacement of moving objects. Depending on the design of the spring-mass-damping system, however, it is also possible to detect dynamic (AC) accelerations with amplitudes up to ± 50 g and within a frequency response range of up to 1.6 kHz ($\pm 5\%$) or 2.1 kHz (± 3 dB). Other advantages of capacitive accelerometers are their outstanding temperature stability, excellent response behavior and achievable resolution.

Description

The accelerometers of the ASC CS series are based on proven MEMS technology with a capacitive operating principle. The integrated electronic circuitry enables a single-ended analog current output of 4-20 mA and flexible power supply voltage from 8 to 30 VDC. The models of the ASC CS series feature broadband noise of $<0.65 \mu\text{A}$ and are used in applications that are requiring extremely long cables (>100 m) or very high EMC immunity.

The sensors ASC CS-1511LN and ASC CS-1611LN feature a lightweight, reliable aluminum housing with protection class IP67 and an integrated cable with configurable length and connectors.

Due to their loss-free signal transmission, even in the case of very long cables, the sensors of the ASC CS series are used in continuous condition monitoring and structural health monitoring (SHM), such as infrastructure monitoring in rail transport or structural analysis of bridges.

Features

- Low Noise Current Output
- Loss-free Signal Transmission
- Very High EMC Immunity
- DC Response, Gas damped
- High Shock Resistance
- Excellent Offset and Scale Factor Stability

Options

- Customized Cable Length
- Customized Connector
- Stainless-Steel Housing (protection class IP68)

Applications

- Structural Health Monitoring
- Infrastructure Monitoring
- Renewable Energy and Industrial Applications

More applications in several markets are figured out on our web page www.asc-sensors.de

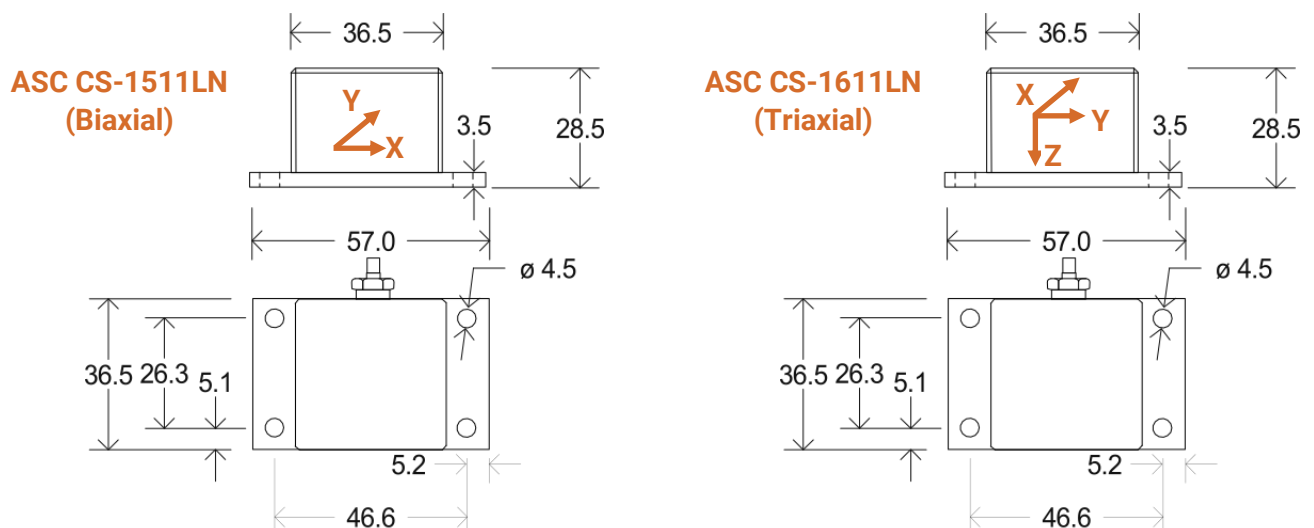

MEMS Capacitive Accelerometer

Typical Specification

Dynamic

Measurement Range	g	±2	±5	±10	±50
Scale Factor (sensitivity)	mA/g	4.0	1.6	0.8	0.16
Noise Density	µg/√Hz	10	15	20	100
Frequency Response Range (±5 %)	Hz	0 to 250	0 to 400	0 to 700	0 to 1600
Frequency Response Range (±3 dB)	Hz	0 to 525	0 to 800	0 to 1100	0 to 2100
Amplitude Non-Linearity	% FSO	<0.15 (typ) <0.5 (max)			
Transverse Sensitivity	%	<2 (typ) <3 (max)			

Electrical

Power Supply Voltage	V	8 to 30			
Operating Current Consumption	mA	<40			
Offset (bias)	mA	12			
Broadband Noise (over frequency range ±5 %)	µA	<0.65	<0.5	<0.5	<0.65
Output Impedance	Ω	90			
Isolation		Case isolated			

Environmental

Temperature Coefficient of the Scale Factor (max)	ppm/K	±200			
Temperature Coefficient of the Offset (max)	mg/K	±0.8	±2	±4	±20
Operating Temperature Range	°C	-20 to +70			
Storage Temperature Range	°C	-30 to +80			
Shock Limit (max peak)	g	2000	2000	5000	5000
Protection Class		IP67			

Physical

Sensing Element	MEMS Capacitive				
Case Material	Anodized Aluminum				
Connector at Cable End	Optional				
Mounting	Adhesive				
Weight (without cable)	gram	65			
Cable for ASC CS-1511LN	55 gram per meter 6 x 0.25 mm ² Polyvinylchlorid (PVC) Diameter 5.7 mm				
Cable for ASC CS-1611LN	35 gram per meter 9 x 0.14 mm ² Polyurethane (PUR) Diameter 4.95 mm				

MEMS Capacitive Accelerometer

Sensor Calibration

Factory Calibration (supplied with the sensor)

Part Number		#16722	#16724	#16726	#16728	#16723	#16725	#16727	#16729
Number of sensitive Directions		ASC CS-1511LN: biaxial				ASC CS-1611LN: triaxial			
Measurement Range (sensor)	g	±2	±5	±10	±50	±2	±5	±10	±50
Applied Frequency (min)	Hz	1	10	10	10	1	10	10	10
Applied Frequency (max)	Hz	100	400	700	1600	150	400	700	1600
Input Amplitude	m/s ²	5	5	50	200	5	5	50	200
Reference Frequency for Determination of Scale Factor	Hz	16	80	80	80	16	80	80	80

Calibration according DIN ISO 17025 (order separately)

Part Number		#16738	#16740	#16742	#16744	#16739	#16741	#16743	#16745
Number of sensitive Directions		ASC CS-1511LN: biaxial				ASC CS-1611LN: triaxial			
Measurement Range (sensor)	g	±2	±5	±10	±50	±2	±5	±10	±50
Applied Frequency (min)	Hz	0.5	10	10	10	0.5	10	10	10
Applied Frequency (max)	Hz	150	800	1100	2100	150	800	1100	2100
Input Amplitude	m/s ²	5	5	50	200	5	5	50	200
Reference Frequency for Determination of Scale Factor	Hz	16	80	80	80	16	80	80	80

Remarks:

- The conversion factor 1 g corresponds to 9.80665 m/s².
- If any other calibration procedure is required, don't hesitate to contact us. Our services include both factory calibration and calibration in accordance with DAkkS guidelines.
- Furthermore, sensors have to be calibrated regularly to ensure accurate and precise results. On request we will be glad to remind you of the next scheduled calibration of your sensors.

ASC CS-1511LN: Cable Code / Pin Configuration (6 Wire System)

Pin	Color Code	Description
1	Supply +	White X-Axis: power supply voltage +8 to +30 VDC
2	Supply -	Brown X-Axis: power GND
3	Signal	Green X-Axis: single-ended analog output current signal
4	Supply +	Pink Y-Axis: power supply voltage +8 to +30 VDC
5	Supply -	Yellow Y-Axis: power GND
6	Signal	Grey Y-Axis: single-ended analog output current signal

ASC CS-1511LN: Cable Configuration

6 Wire System - 6L

Separate power supply for all axes, no cable switch



6 Wire System - 6L2

Separate power supply for all axes, including cable switch

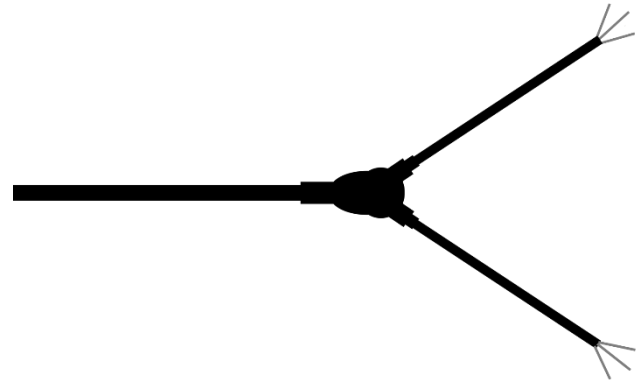

ASC CS-1611LN: Cable Code / Pin Configuration (9 Wire System)

Pin	Color Code	Description
1	Supply +	Violet X-Axis: power supply voltage +8 to +30 VDC
2	Supply -	Grey X-Axis: power GND
3	Signal	Yellow X-Axis: single-ended analog output current signal
4	Supply +	Blue Y-Axis: power supply voltage +8 to +30 VDC
5	Supply -	Brown Y-Axis: power GND
6	Signal	White Y-Axis: single-ended analog output current signal
7	Supply +	Red Z-Axis: power supply voltage +8 to +30 VDC
8	Supply -	Black Z-Axis: power GND
9	Signal	Green Z-Axis: single-ended analog output current signal

ASC CS-1611LN: Cable Configuration

9 Wire System - 9L

Separate power supply for all axes, no cable switch



9 Wire System - 9L3

Separate power supply for all axes, including cable switch

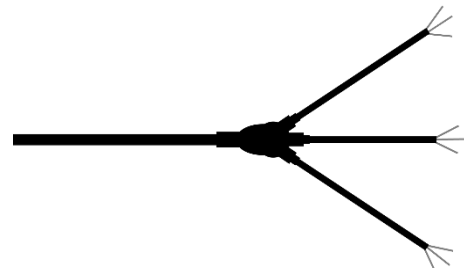

MEMS Capacitive Accelerometer

Ordering Information

Series	Model	- Range [g]	- Cable Length [m]	Connector & Pinout	- Cable Configuration
ASC CS	-1511LN (biaxial)	002	6	A	6L
		005			6L2
		010			
		050			

Example:

ASC CS-1511LN-002-6A-6L

Series	Model	- Range [g]	- Cable Length [m]	Connector & Pinout	- Cable Configuration
ASC CS	-1611LN (triaxial)	002	6	A	9L
		005			9L3
		010			
		050			

Example:

ASC CS-1611LN-002-6A-9L

Ordering information are based on standard configurations. All customized versions regarding connector and/or pinout will lead to a corresponding product match code:

- Standard length of the integrated cable is 6 meters.
- Different customized cable lengths >100 meters are possible on request.
- Standard version has no connector at the cable end which is identified by "A" in the product match code. However, it is possible to assemble almost all connector types during production.

MEMS Capacitive Accelerometer

Safety Precaution for Installing and Operating

This data sheet is a part of the product. Read the data sheet carefully before using the product and keep it available for future operation. Handling, electrical connections, mounting or any other work performed at the sensor must be carried out by authorized experts only. Appropriate safety precautions must be taken to exclude any risk of personal injury and damage to operating equipment as a result of a sensor malfunction.

Handling

The sensor is packaged in a reliable housing to protect the sensing elements and integrated electronic components from the ambient environment. However, poor handling of the product can lead to damages that may not be visible and cause electrical failure or reliability issues. Handle the component with caution:

- Avoid shocks and impacts on the housing, such as dropping the sensor on hard surface
- Never move the sensor by pulling the cable
- Make sure that the sensor is used within the specified environmental conditions
- Transport and store the sensor in its original or similar packaging
- The sensor should be mounted on a stable flat surface with all screws tightened or other mounting options
- When adhesives are used to mount the sensors, please select the corresponding products according to permanent or removable mounting, ambient temperature range as well as quality of the mounting surface
- Avoid any deformation during mounting the sensor
- Mounting tolerances may have an influence on the measured result

Electrical

ASC's inertial sensors are working with many established data acquisition systems. However, make sure that a proper DAQ is used, for the corresponding operation principle of the sensor. Furthermore, suitable precautions shall be employed during all phases of shipment, handling and operating:

- Active sensor pins are susceptible to damage due to electrostatic discharge (ESD)
- Make sure that the sensor is used within the specified electrical conditions
- Check all electrical connections prior to initial setup of the sensor
- Completely shield the sensor and connecting cable
- Do not perform any electrical modifications at the sensor
- Do not perform any adaptations on the wiring or connectors while the device under power
- Never plug or unplug the electrical connection while the sensor is under power
- When a certain pin is not used during operation, make sure that the pin is insulated

Quality

- We have a quality management system according to ISO 9001:2015.
- The Deutsche Akkreditierungsstelle GmbH (DAkkS) has awarded to our calibration laboratory the DIN EN ISO/IEC 17025:2018 accreditation for calibrations and has confirmed our competence to perform calibrations in the field of mechanical acceleration measurements. The registration number of the certificate is **D-K-18110-01-00**.
- All ASC products are **CE**-compliant.

Made in Germany



analyzing



monitoring



testing



measuring