

MEMS Capacitive Accelerometer

ASC ECO-x311

Uniaxial, Biaxial, Triaxial

MEMS Capacitive

Measurement Range: ± 2 to ± 40 g

Frequency Range ($\pm 5\%$): DC to 630 Hz

Scale Factor: 60 mV/g to 1200 mV/g

Aluminum Housing (IP68)

Made in Germany



MEMS Capacitive Accelerometer

The key components in capacitive accelerometers are high-quality micro-electro-mechanical systems (MEMS). This technology enables the measurement of static (DC) and constant accelerations, which can be used to calculate the velocity and displacement of moving objects. Depending on the design of the spring-mass-damping system, however, it is also possible to detect dynamic (AC) accelerations with amplitudes up to ± 40 g and within a frequency response range of up to 630 Hz ($\pm 5\%$) or 2.4 kHz (± 3 dB).

Description

The industrial accelerometers of type ASC ECO-x311 are based on proven MEMS technology and capacitive operating principle. They featuring a wide frequency response range from 0 Hz to 2.4 kHz (± 3 dB) and an extremely robust design with shock resistance up to 10,000 g. The integrated electronic circuitry enables a differential analog voltage output (± 2.4 V FSO) and flexible power supply voltage from 5 to 40 VDC.

The sensors feature a lightweight, reliable aluminum housing with protection class IP68 and an integrated cable with configurable length and connectors.

The accelerometers feature a flat design that allows quick and easy mounting. This makes them ideal for measuring applications in hard-to-access installations, e.g. condition monitoring systems for industrial machinery.

Features

- Low Noise Differential Voltage Output
- DC Response, Gas damped
- Very High Shock Resistance
- Low Current Consumption

Options

- Customized Cable Length
- Customized Connector
- Selectable Axes Configuration

Applications

- General Industrial Test&Measurement
- Robotics and Automation
- Condition Monitoring

More applications in several markets are figured out on our web page www.asc-sensors.de

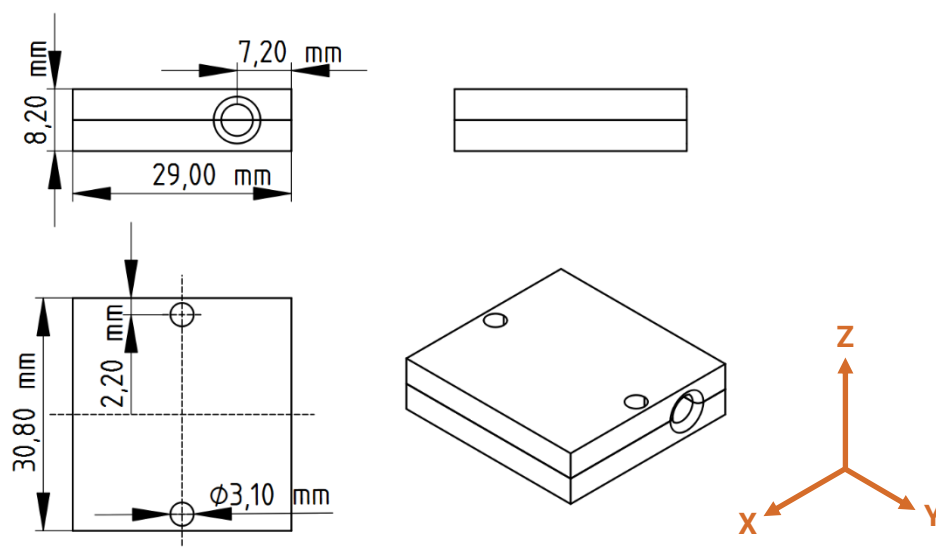

Typical Specification

Dynamic

Measurement Range	g	±2	±4	±8	±10	±20	±40
Scale Factor (sensitivity)	mV/g	1200	600	300	240	120	60
Noise Density	µg/√Hz	22.5	25.0	30.0	75.0	80.0	90.0
Frequency Response Range (±5 %)	Hz	DC to 630					
Frequency Response Range (±3 dB)	Hz	DC to 1500			DC to 2400		
Amplitude Non-Linearity	%	0.1	0.4	1.1	0.1	0.5	1.3
Transverse Sensitivity	%	<1 (typ)					

Electrical

Power Supply Voltage	V	5 to 40					
Operating Current Consumption	mA	< 15					
Offset (bias)	mV	±100	±50	±25	±100	±50	±25
Broadband Noise (over frequency range ±5 %)	µV	<170 (min) <850 (max)					
Isolation		Case Isolated					

Environmental

Temperature Coefficient of the Scale Factor (typ)	ppm/K	±100					
Temperature Coefficient of the Offset	mg/K	±0.1 (typ) ±0.15 (max)			±0.2 (typ) ±0.75 (max)		
Operating Temperature Range	°C	-20 to +125 -40 to +125 on request					
Storage Temperature Range	°C	-20 to +125 -40 to +125 on request					
Shock Limit	g	5000 (0.5 ms, unpowered)			10000 (0.1 ms, unpowered and powered)		
Protection Class		IP68 Please note: the housing is hermetically sealed and therefore not repairable.					

Physical

Sensing Element		MEMS Capacitive					
Case Material		Anodized Aluminum					
Connector at Cable End		Optional					
Mounting		Adhesive Screw Holes					
Weight (without cable)	gram	15					
Cable		30 gram per meter AWG 30 Polyurethane (PUR) Diameter 4.5 mm					

Sensor Calibration

Factory Calibration (supplied with the sensor)

Part Number		#12054	#17873	#17874	#14496	#17485	#17143
Number of Sensitive Directions		Uniaxial Biaxial			Triaxial		
Measurement Range (sensor)	g	±2	±4 and ±8	±10 to ±40	±2	±4 and ±8	±10 to ±40
Applied Frequency (min)	Hz	1	10	10	1	10	10
Applied Frequency (max)	Hz	100	630	630	100	630	630
Input Amplitude	m/s ²	5	15	50	5	15	50
Reference Frequency for Determination of Scale Factor	Hz	16	80	80	16	80	80

Calibration according DIN ISO 17025 (order separately)

Part Number		#14512	#17876	#17875	#14513	#17877	#17524
Number of Sensitive Directions		Uniaxial Biaxial			Triaxial		
Measurement Range (sensor)	g	±2	±4 and ±8	±10 to ±40	±2	±4 and ±8	±10 to ±40
Applied Frequency (min)	Hz	0.5	10	10	0.5	10	10
Applied Frequency (max)	Hz	150	1500	2400	150	1500	2400
Input Amplitude	m/s ²	5	15	50	5	15	50
Reference Frequency for Determination of Scale Factor	Hz	16	80	80	80	80	80

Please note: The conversion factor 1 g corresponds to 9.80665 m/s². If any other calibration procedure is required, don't hesitate to contact us.

Cable Configuration

4 Wire System - 4L (Uniaxial)

Common power supply for all axes, no cable switch



6 Wire System - 6L (Biaxial)

Common power supply for all axes, no cable switch



8 Wire System - 8L (Triaxial)

Common power supply for all axes, no cable switch



6 Wire System - 6L2 (Biaxial)

Common power supply for all axes, including cable switch

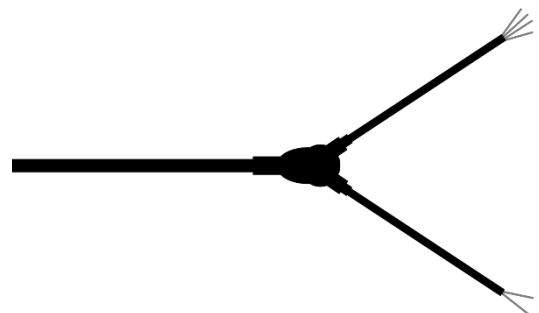

8 Wire System - 8L3 (Triaxial)

Common power supply for all axes, including cable switch

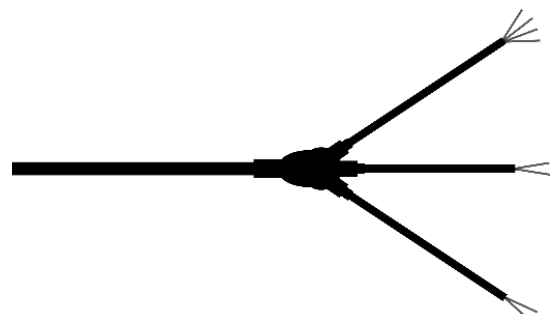

Cable Code / Pin Configuration (8 Wire System) including common Power Supply for all Axes

Pin	Color Code	Description
1	Supply +	Red Power: supply voltage +5 to +40 VDC
2	Supply -	Black Power: GND
3	Signal +	Green/Violet X-Axis: positive, analog output voltage signal for differential mode
4	Signal -	White/Violet X-Axis: negative, analog output voltage signal for differential mode
5	Signal +	Green/Grey Y-Axis: positive, analog output voltage signal for differential mode
6	Signal -	White/Grey Y-Axis: negative, analog output voltage signal for differential mode
7	Signal +	Green Z-Axis: positive, analog output voltage signal for differential mode
8	Signal -	White Z-Axis: negative, analog output voltage signal for differential mode

The cable code and pin configuration are based on a triaxial sensor. However, referring to the ordering information there are different axes configurations available. That means the standard uniaxial version is not fixed to Z-axis but could be fabricated in Y or X configuration. Furthermore, the biaxial version is not fixed to YX but is also available in ZY or ZX configuration. However, the color code of the integrated cable for the corresponding axis will be always the same for all possible sensor configurations.

Please, contact us for further details and options.

Ordering Information

Series	Sensitive Directions	Model	Housing Material	Range [g]	Axes Configuration	Cable Length [m]	Connector & Pinout	Cable Configuration
ASC ECO	1 (Uniaxial)	31	1 (Aluminum)	002	Z (Uniaxial)	6	A	4L (Uniaxial)
	2 (Biaxial)			004	Y (Uniaxial)			6L (Biaxial)
	3 (Triaxial)			008	X (Uniaxial)			6L2 (Biaxial)
				010	YX (Biaxial)			8L (Triaxial)
				020	ZY (Biaxial)			8L3 (Triaxial)
				040	ZX (Biaxial)			

Example:

ASC ECO-1311-002-Z-6A-4L

Ordering information are based on standard configurations. All customized versions regarding connector and/or pinout will lead to a corresponding product match code:

- Standard length of the integrated cable is 6 meters. However, different customized cable lengths are possible on request.
- Standard version has no connector at the cable end which is identified by "A" in the product match code. However, it is possible to assemble almost all connector types during production.
- Furthermore, sensors have to be calibrated regularly to ensure accurate and precise results. Our services include both factory calibration and calibration in accordance with DAkkS guidelines. On request we will be glad to remind you of the next scheduled calibration of your sensors.

Safety Precaution for Installing and Operating

This data sheet is a part of the product. Read the data sheet carefully before using the product and keep it available for future operation. Handling, electrical connections, mounting or any other work performed at the sensor must be carried out by authorized experts only. Appropriate safety precautions must be taken to exclude any risk of personal injury and damage to operating equipment as a result of a sensor malfunction.

Handling

The sensor is packaged in a reliable housing to protect the sensing elements and integrated electronic components from the ambient environment. However, poor handling of the product can lead to damages that may not be visible and cause electrical failure or reliability issues. Handle the component with caution:



- Avoid shocks and impacts on the housing, such as dropping the sensor on hard surface
- Never move the sensor by pulling the cable
- Make sure that the sensor is used within the specified environmental conditions
- Transport and store the sensor in its original or similar packaging
- The sensor should be mounted on a stable flat surface with all screws tightened or other mounting options
- When adhesives are used to mount the sensors, please select the corresponding products according to permanent or removable mounting, ambient temperature range as well as quality of the mounting surface
- Avoid any deformation during mounting the sensor
- Mounting tolerances may have an influence on the measured result

Electrical

ASC's inertial sensors are working with many established data acquisition systems. However, make sure that a proper DAQ is used, for the corresponding operation principle of the sensor. Furthermore, suitable precautions shall be employed during all phases of shipment, handling and operating:

- Active sensor pins are susceptible to damage due to electrostatic discharge (ESD)
- Make sure that the sensor is used within the specified electrical conditions
- Check all electrical connections prior to initial setup of the sensor
- Completely shield the sensor and connecting cable
- Do not perform any electrical modifications at the sensor
- Do not perform any adaptations on the wiring or connectors while the device under power
- Never plug or unplug the electrical connection while the sensor is under power
- When a certain pin is not used during operation, make sure that the pin is insulated

Quality

- We have a quality management system according to ISO 9001:2015.
- The Deutsche Akkreditierungsstelle GmbH (DAkkS) has awarded to our calibration laboratory the DIN EN ISO/IEC 17025:2018 accreditation for calibrations and has confirmed our competence to perform calibrations in the field of mechanical acceleration measurements. The registration number of the certificate is **D-K-18110-01-00**.
- ASC ECO CS products are   -compliant.

Made in Germany



analyzing



monitoring



testing



measuring